



Straight Line, Side Opening Deadend Clamps

Iron Straight Line, Side Opening Deadend Clamps

Features

- U-Bolts are captive
- Spring loaded side opening - shipped in open position

Material

Body and Keeper: Ductile iron hot dip galvanized
 Cotter Pin and Compression Spring: Stainless steel
 Hardware: Steel hot dip galvanized ASTM A-153

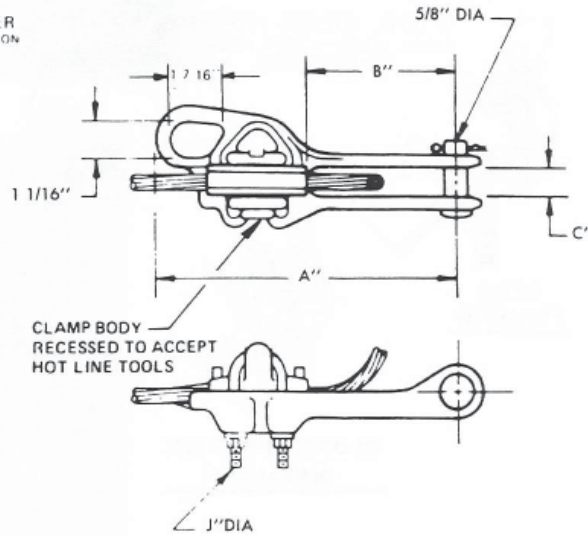
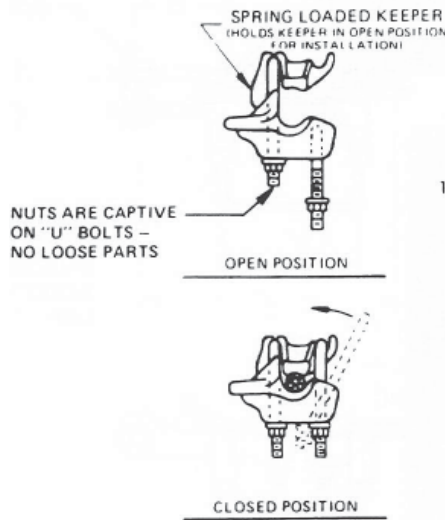

Catalog Number	Conductor Range			U-Bolts		Dimensions			Ultimate Strength		Weight /100 (lbs)
	Inches	ACSR	AL or Cu	No	Size	A	B	C	Body	Sag Eye	
HDSO-47-F	0.190 - 0.470	#6 - 2/0	#4 - 3/0	2	3/8	7.75	4.31	0.75	8000	5000	300
HDSO-57-F	0.250 - 0.570	#4 - 4/0	#2 - 4/0	2	3/8	8.38	4.50	0.75	9000	6000	400
HDSO-70-F	0.310 - 0.700	#2 - 336.4	#1 - 350	2	3/8	8.75	4.75	0.81	10000	7000	400

Notes:

- 1) Add suffix "-S" for socket fitting
- 2) Add suffix "-C" for clevis fitting
- 3) Add suffix "-HP" for hex clevis pin
- 4) Recommended torque on U-Bolts: 3/8" - 20-25 ft/lbs

Aluminum Straight Line, Side Opening Deadend Clamps with Stirrup

Material

Body and Keeper: Aluminum Alloy
 Cotter Pin and Compression Spring: Stainless Steel
 Hardware: Steel hot dip galvanized
 Stirrup: Copper

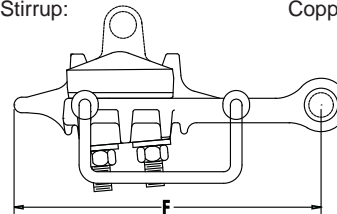
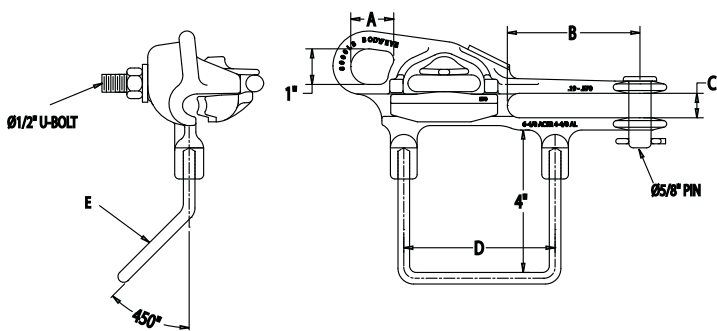

Catalog Number	AWG/MCM ACSR	AWG/MCM Aluminum	Dimensions								Ultimate Strength		Weight /100 (lbs)
			A	B	C	D	E	F	G	J	Body	Sag Eye	
ASOS-570-N	4 - 4/0	4 - 4/0	8.62	3.75	0.69	1/0 Sol. Cu	4.25	1.19	1	0.5	8000	8000	176
ASOS-858-TN	4 - 556 - 5	2 - 5565									8000	6000	250

Notes:

- 1) Add suffix "E" if for lifting eye on keeper